

## Web Dynamics Ltd

Moss Lane  
Blackrod  
Bolton  
Lancashire BL6 5JB  
Tel: 01204 695666 Fax: 01204 695333  
e-mail: web@webdynamics.co.uk  
website: www.webdynamics



Agrément Certificate  
**09/4619**  
Product Sheet 1

## WEB WALL BREATHER MEMBRANES

### WEB UV 10

#### PRODUCT SCOPE AND SUMMARY OF CERTIFICATE

This Certificate relates to Web UV 10, a breather membrane, for use as a breather membrane in timber-frame wall construction.

#### AGRÉMENT CERTIFICATION INCLUDES:

- factors relating to compliance with Building Regulations where applicable
- factors relating to additional non-regulatory information where applicable
- independently verified technical specification
- assessment criteria and technical investigations
- design considerations
- installation guidance
- regular surveillance of production
- formal three-yearly review.

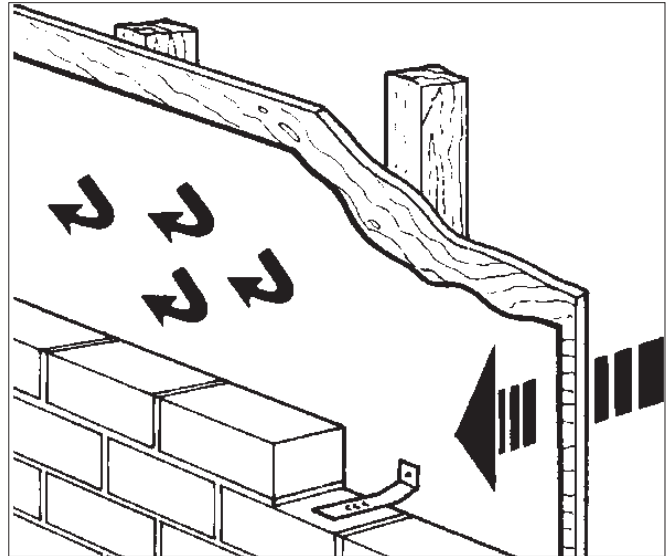

#### KEY FACTORS ASSESSED

**Weather-tightness** — the product will contribute to protecting a wall against water penetration (see section 5).

**Risk of condensation** — the product has a low resistance to water vapour transmission and will reduce the risk of interstitial condensation (see section 6).

**Strength** — the product has adequate strength to resist damage during the construction of the wall (see section 7).

**Durability** — the product will have a service life comparable to similar elements in the construction, eg vapour control layers (see sections 5.2 and 10).

The BBA has awarded this Agrément Certificate to the company named above for the product described herein. This product has been assessed by the BBA as being fit for its intended use provided it is installed, used and maintained as set out in this Certificate.

On behalf of the British Board of Agrément



Simon Wroe  
Head of Approvals — Materials



Greg Cooper  
Chief Executive

Date of First issue: 7 April 2009

*The BBA is a UKAS accredited certification body — Number 113. The schedule of the current scope of accreditation for product certification is available in pdf format via the UKAS link on the BBA website at [www.bbacerts.co.uk](http://www.bbacerts.co.uk)*

*Readers are advised to check the validity and latest issue number of this Agrément Certificate by either referring to the BBA website or contacting the BBA direct.*

British Board of Agrément  
Bucknalls Lane  
Garston, Watford  
Herts WD25 9BA

©2009

tel: 01923 665300  
fax: 01923 665301  
e-mail: [mail@bba.star.co.uk](mailto:mail@bba.star.co.uk)  
website: [www.bbacerts.co.uk](http://www.bbacerts.co.uk)

# Regulations

In the opinion of the BBA, Web UV 10, if used in accordance with the provisions of this Certificate, will meet or contribute to meeting the relevant requirements of the following Building Regulations:



## The Building Regulations 2000 (as amended) (England and Wales)

Requirement:	C2(b)	Resistance to moisture
Comment:		The product will contribute to a wall meeting this Requirement. See section 5.1 of this Certificate.
Requirement:	C2(c)	Resistance to moisture
Comment:		The product can contribute to a wall meeting this Requirement with respect to interstitial condensation. See section 6.1 of this Certificate.
Requirement:	Regulation 7	Materials and workmanship
Comment:		The product is acceptable. See section 10 and the <i>Installation</i> part of this Certificate.



## The Building (Scotland) Regulations 2004 (as amended)

Regulation:	8(1)(2)	Fitness and durability of materials and workmanship
Comment:		The product satisfies the requirements of this Regulation. See sections 9 and 10 and the <i>Installation</i> part of this Certificate.
Regulation:	9	Building standards — construction
Standard:	3.10	Precipitation
Comment:		The product will contribute to a wall satisfying clauses 3.10.1 <sup>(1)(2)</sup> and 3.10.5 <sup>(1)(2)</sup> of this Standard. See section 5.1 of this Certificate.
Standard:	3.15	Condensation
Comment:		The product can contribute to a wall satisfying clauses 3.15.1 <sup>(1)</sup> and 3.15.5 <sup>(1)</sup> of this Standard, with respect to interstitial condensation. See section 6.1 of this Certificate.
Regulation:	12	Building standards — conversions
Comment:		All comments given for this product under Regulation 9, also apply to this Regulation, with reference to clause 0.12.1 <sup>(1)(2)</sup> and Schedule 6 <sup>(1)(2)</sup> . (1) Technical Handbook (Domestic). (2) Technical Handbook (Non-Domestic).



## The Building Regulations (Northern Ireland) 2000 (as amended)

Regulation:	B2	Fitness of materials and workmanship
Comment:		The product is acceptable. See section 10 and the <i>Installation</i> part of this Certificate.
Regulation:	B3(2)	Suitability of certain materials
Comment:		The product does not normally require maintenance. See section 9 of this Certificate.
Regulation:	C4(b)	Resistance to ground moisture and weather
Comment:		The product will contribute to a wall satisfying this Regulation. See section 5.1 of this Certificate.
Regulation:	C5	Condensation
Comment:		The product can contribute to a wall to satisfying this Regulation. See section 6.1 of this Certificate.

## Construction (Design and Management) Regulations 2007

## Construction (Design and Management) Regulations (Northern Ireland) 2007

Information in this Certificate may assist the client, CDM co-ordinator, designer and contractors to address their obligations under these Regulations.

See section: 1 *Description* (1.2).

# Non-regulatory Information

## NHBC Standards 2008

NHBC accepts the use of Web UV 10, when installed and used in accordance with this Certificate, in relation to *NHBC Standards*, Chapter 6.2 *External timber framed walls*.

## Zurich Building Guarantee Technical Manual 2007

In the opinion of the BBA, Web UV 10, when installed and used in accordance with this Certificate, satisfies the requirements of the *Zurich Building Guarantee Technical Manual*, Section 4 *Superstructure*, Sub-section *External walls — timber frame*.

## General

This Certificate relates to Web UV 10, for use as a breather membrane in timber-frame wall construction with a cavity and conventional masonry, weatherboarding, tile or slate cladding.

Breather membranes are suitable for use in timber-frame constructions, either factory or site applied.

## Technical Specification

### 1 Description

1.1 Web UV 10 is manufactured by thermally bonding two layers of spunbond polypropylene with a microporous film between the two layers, to form a breathable waterproof membrane. For recycling purposes, the polymer content of the membrane is 100% polypropylene.

1.2 The product's nominal characteristics are given below:

Mass per unit area (gm <sup>-2</sup> )	
top layer	70
bottom layer	17
total	112
Roll length (m) <sup>(1)</sup>	50
Roll width (m) <sup>(1)</sup>	1 and 1.5
Colour <sup>(2)</sup>	
top surface	black
bottom surface	white

(1) Other sizes available to order.

(2) Other colours available to order.

1.3 Quality control checks on the finished product include:

- weight
- tensile strength and elongation
- nail tear
- hydrostatic head.

### 2 Delivery and site handling

2.1 The membrane is delivered to site in rolls wrapped in polyethylene. Labels bearing the company name, product name, product code, dimensions and the BBA identification mark incorporating the number of this Certificate are attached to each roll.

2.2 The rolls should be stored on their sides, on a level, clean surface, under cover and protected from sunlight.

## Assessment and Technical Investigations

The following is a summary of the assessment and technical investigations carried out on Web UV 10.

## Design Considerations

### 3 General

3.1 Web UV 10 is suitable for use in timber-frame constructions, either factory or site applied.

3.2 In the absence of other guidance, suitable timber-frame constructions are defined as those designed and built in accordance with *NHBC Standards*, Section 6.2.

3.3 The product meets the NHBC requirements for minimum water penetration resistance and minimum tear resistance in any direction for sites defined as very severe exposure (see section 14, Tables for *Physical properties — directional* and *Physical properties — general*).

3.4 The membrane may be damaged by high winds, careless handling or by vandalism and should not be left uncovered for longer than is absolutely necessary. Any damaged areas must be repaired or replaced before completion in accordance with section 13.

### 4 Practicability of installation

The product can be installed readily by operatives experienced with this type of product.

### 5 Weathertightness



5.1 The product resists liquid water penetration and wind-blown snow and will protect the sheathing and frame from external moisture (see section 14, Table for *Physical properties — general*).

5.2 The period prior to the installation of the brickwork should be kept to a minimum. The membranes should not be used as a temporary waterproof covering during this time.

## 6 Risk of condensation



6.1 The product has a design resistance to water vapour transmission of less than or equal to  $0.6 \text{ MNsg}^{-1}$  and is defined as a 'breather membrane' in accordance with BS 5250 : 2002. Therefore, it will contribute towards minimising the risk of interstitial condensation in suitably designed walls (see section 14, Table for *Physical properties — general*).

6.2 The risk of condensation occurring within the wall of a timber-frame building will depend upon the properties and vapour resistance of other materials used in the construction, the internal and external conditions and the effectiveness of the internal vapour control layer.

## 7 Strength

7.1 The product will resist the normal loads associated with construction and installation into timber-frame constructions.

7.2 The product is not adversely affected by water and retains its properties when wet (see section 14, Table for *Physical properties — directional*).

## 8 Properties in relation to fire

8.1 The product will have similar properties to polyolefin membranes in relation to fire, tending to burn and shrink away from the heat source. The product is unclassifiable in terms of the Building Regulations and this should be considered when assessing the overall fire risk.

8.2 Cavity barriers should be used to satisfy the requirements of the national Buildings Regulations.

8.3 The product has been classified as Class E in accordance with BS EN 13501-1 : 2002.

## 9 Maintenance



As the product is confined within a wall construction and it has suitable durability (see section 10), maintenance is not required. However, it must be ensured that damage occurring before enclosure is repaired (see section 13).

## 10 Durability



The product will be virtually unaffected by the normal conditions found in a timber-frame wall and will have a life comparable with other similar elements of construction, eg vapour control layers.

# Installation

## 11 General

Web UV 10 must be installed in accordance with the Certificate holder's instructions and the recommendations given in *NHBC Standards*, Section 6.2, where appropriate.

## 12 Procedure

### Lapping and jointing

12.1 The membrane should be fixed in such a way as to shed water away from the sheathing, and below the lowest timber. Upper layers must be lapped over lower layers.

12.2 Horizontal laps should be at least 100 mm and vertical laps 150 mm. Vertical laps should be staggered wherever possible (see Figure 1).

Figure 1 Laps (dimensions in mm)

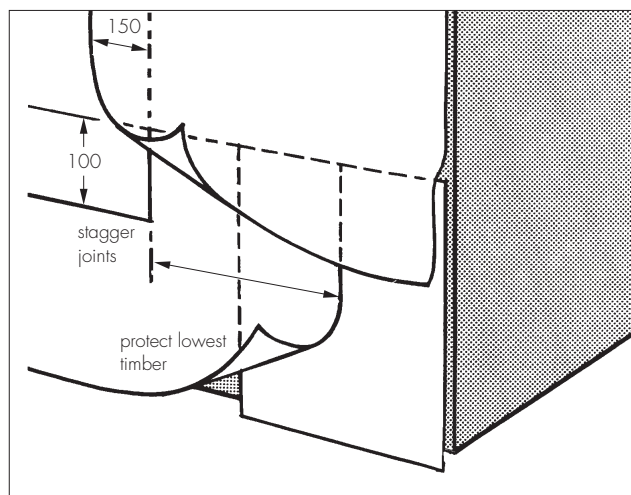

## Fixing

12.4 The membrane must be secured at regular intervals with nails and staples to prevent damage by wind.

12.5 Nails should be of galvanized or sherardized mild steel, austenitic stainless steel, phosphor bronze or silicon bronze, and staples should be of austenitic stainless steel.

## Marking stud positions

12.6 It is essential that the positions of studs are marked to enable wall tie fixing.

## Lowest timbers

12.7 It is essential that the lowest timbers in the wall are protected by the breather membrane.

## 13 Repair

Damage to the membrane must be repaired prior to the installation of the external walls or cladding by laying another sheet over the damaged area and sealing it correctly, ensuring water is shed away from the sheathing.

# Technical Investigations

## 14 Tests

14.1 Samples of Web UV 10 were obtained from the Certificate holder for testing. The results of the tests carried out by, or on behalf of, the BBA are summarised in Tables 1 and 2.

Table 1 Physical properties — directional

Test (units)	Mean result		Method <sup>(1)</sup>
	Longitudinal	Transverse	
Tensile strength (N per 50 mm)			BS EN 13859-2 Annex A
unaged	211	142	
UV/heat aged <sup>(2)</sup>	176	90	
Elongation at break (%)			BS EN 13859-2 Annex A
unaged	41	54	
UV/heat aged <sup>(2)</sup>	24	23	
Tear resistance – nail (N)	148	198	BS EN 13859-2 Annex B
Dimensional stability (%)	0	–0.2	BS EN 1107-2

(1) The test documents are detailed in the *Bibliography*. Numbers in the table refer to sections/parts of the various documents.

(2) Light ageing for 336 hours of UVA at 50°C followed by heat ageing for 90 days at 70°C.

Table 2 Physical properties — general

Test (units)	Mean result	Method <sup>(1)</sup>
Water vapour transmission ( $\text{gm}^{-2}\text{day}^{-1}$ )	983	BS 3177 (25°C/75% RH)
Vapour resistance ( $\text{MNsg}^{-1}$ )	0.21	BS 3177 (25°C/75% RH)
Hydrostatic pressure (mm)		BS EN 20811
minimum	2270	
mean	4520	
Resistance to water penetration		BS EN 13859-2
unaged	Class W1	
UV/heat aged <sup>(2)</sup>	Class W1	
Eosin test	Pass	BS 4016
Burst strength ( $\text{kNm}^{-2}$ )	507	BS 3137

(1) The test documents are detailed in the *Bibliography*. Numbers in the table refer to sections/parts of the various documents.

(2) Light ageing for 336 hours of UVA at 50°C followed by heat ageing for 90 days at 70°C.

14.2 An examination was also made of test data on the following properties:

- thickness
- width
- mass per unit area.

## 15 Investigations

15.1 The manufacturing process was assessed, including the method adopted for quality control, and details were obtained of the quality and composition of the materials used.

15.2 Reaction to fire test data to BS EN ISO 11925-2 : 2002 were examined.

## Bibliography

BS 3137 : 1972 *Methods for determining the bursting strength of paper and board*

BS 3177 : 1959 *Method for determining the permeability to water vapour of flexible sheet materials used for packaging*

BS 4016 : 1997 *Specification for flexible building membranes (breather type)*

BS 5250 : 2002 *Code of practice for control of condensation in buildings*

BS EN 1107-2 : 2001 *Flexible sheets for waterproofing — Determination of dimension stability — Plastic and rubber sheets for roof waterproofing*

BS EN 13501-1 : 2002 *Fire classification of construction products and building elements. Classification using test data from reaction to fire tests*

BS EN 13859-2 : 2004 *Flexible sheets for waterproofing — Definitions and characteristics of underlays — Underlays for walls*

BS EN 20811 : 1992 *Textiles — Determination of resistance to water penetration — Hydrostatic pressure test*

BS EN ISO 11925-2 : 2002 *Reaction to fire tests — Ignitability of building products subjected to direct impingement of flame — Single-flame source test*

## 16 Conditions

16.1 This Certificate:

- relates only to the product/system that is named and described on the front page
- is granted only to the company, firm or person named on the front page — no other company, firm or person may hold or claim any entitlement to this Certificate
- is valid only within the UK
- has to be read, considered and used as a whole document — it may be misleading and will be incomplete to be selective
- is copyright of the BBA
- is subject to English law.

16.2 Publications and documents referred to in this Certificate are those that the BBA deems to be relevant at the date of issue or re-issue of this Certificate and include any: Act of Parliament; Statutory Instrument; Directive; Regulation; British, European or International Standard; Code of Practice; manufacturers' instructions; or any other publication or document similar or related to the aforementioned.

16.3 This Certificate will remain valid for an unlimited period provided that the product/system and the manufacture and/or fabrication including all related and relevant processes thereof:

- are maintained at or above the levels which have been assessed and found to be satisfactory by the BBA
- continue to be checked as and when deemed appropriate by the BBA under arrangements that it will determine
- are reviewed by the BBA as and when it considers appropriate.

16.4 In granting this Certificate, the BBA is not responsible for:

- the presence or absence of any patent, intellectual property or similar rights subsisting in the product/system or any other product/system
- the right of the Certificate holder to manufacture, supply, install, maintain or market the product/system
- individual installations of the product/system, including the nature, design, methods and workmanship of or related to the installation
- the actual works in which the product/system is installed, used and maintained, including the nature, design, methods and workmanship of such works.

16.5 Any information relating to the manufacture, supply, installation, use and maintenance of this product/system which is contained or referred to in this Certificate is the minimum required to be met when the product/system is manufactured, supplied, installed, used and maintained. It does not purport in any way to restate the requirements of the Health & Safety at Work etc Act 1974, or of any other statutory, common law or other duty which may exist at the date of this Certificate; nor is conformity with such information to be taken as satisfying the requirements of the 1974 Act or of any statutory, common law or other duty of care. In granting this Certificate, the BBA does not accept responsibility to any person or body for any loss or damage, including personal injury, arising as a direct or indirect result of the manufacture, supply, installation, use and maintenance of this product/system.

